

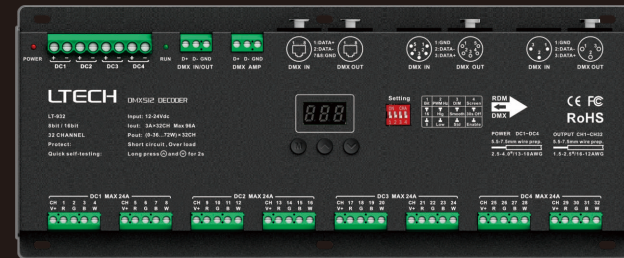

8 bit / 16 bit
4 kinds of DMX interfaces
Shortcut / Over load protection



Product Introduction:

1. Designed for Hi-power multiple channels application, 32 channels output, and up to 2304W output power.
2. Easy operation with digital display and the touch buttons.
3. Support 4 kinds of DMX ports : 3-pin XLR, 5-pin XLR, RJ45 and green terminal (with signal amplifier function).
4. With RDM remote management protocol, the operations can be completed via the RDM master console, such as parameters browsing & setting, DMX address setting, equipment recognition, etc.
5. With shortcut protection and over load protection, as well as warning function when fault.
6. With fast self-testing function.
7. High/low PWM frequency for optional
8. 16bit (65536 levels) / 8bit (256 levels) grey level optional.



Technical Specs:

Model : LT-932
 Input Signal : DMX512/RDM
 Input Voltage : 12-24Vdc
 Current Load : 3A x 32CH Max 96A
 Output Power : (0~36W...72W) x 32CH Max. 2304W
 DMX Interface : 3-pin XLR, 5-pin XLR, RJ45, Green terminal
 Grey Level : 8bit (256 levels) / 16bit (65536 levels)
 Protection: Shortcut / Over load
 Working Temperature : -30°C~65°C
 Dimensions : L300xW122xH39mm
 Package Size : L313xW127xH41mm
 Weight (G.W.) : 1180g



Product Size:

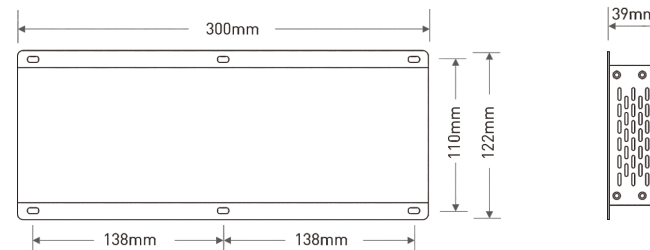

Main Component Description:

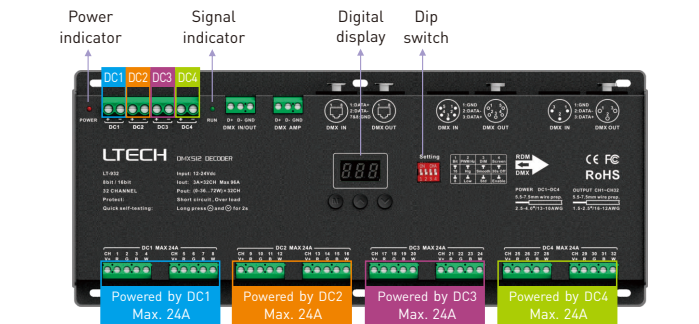

Digital display



- Digital display will enter the locked mode without operating after 15S.
- Long press "M" key to unlock.
- Short press "M" key to switch numbers.
- Press "▲""▼" key to adjust value.

Dip switch



1 Bit	2 PWM Hz	3 DIM	4 Screen
16	Hig	Smooth	30S off
8	Low	Std	Enable

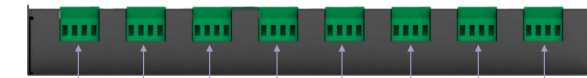
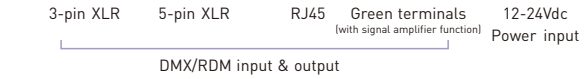

Green terminals LED lamps connection

Wiring Diagram:

1. DMX console connection:



LT-932 is equipped with 4 types DMX terminals for users' selection. The following diagram takes 3-pin XLR as an example, same connecting method for the rest three: RJ45 & 5-pin XLR & green terminal (with amplifier function).

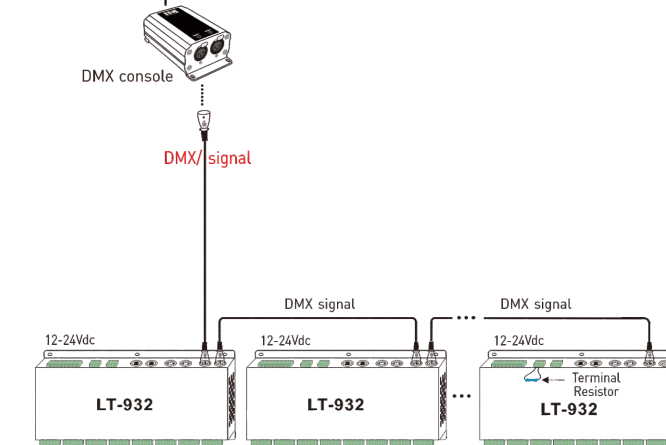

* If the recoil effect occurs because of longer signal line or bad line quality, please try to connect 0.25W 90-120Ω terminal resistor at the end of each line.

2 Connecting LED lights:

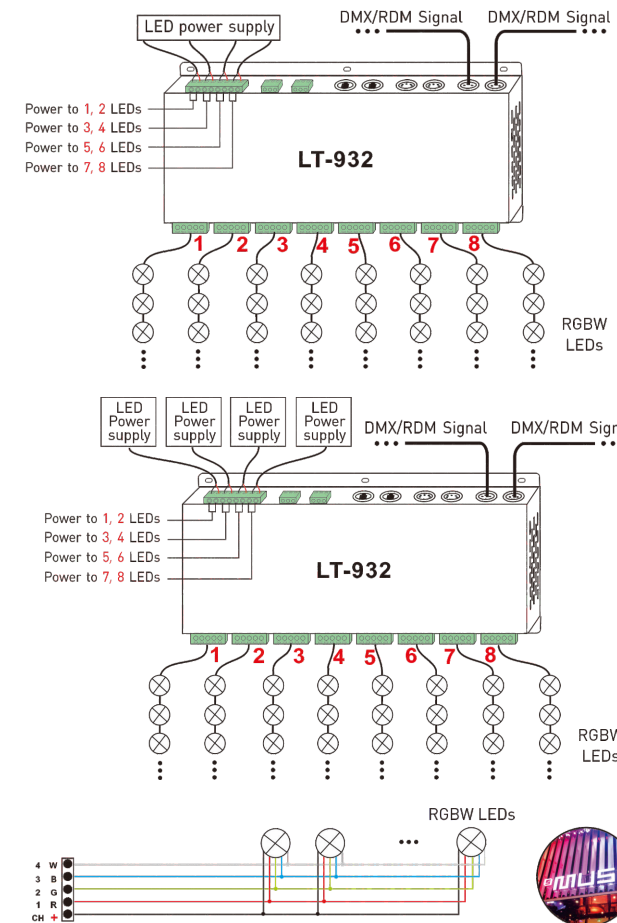

3. The connection diagram of 4 kinds of DMX/RDM terminals:

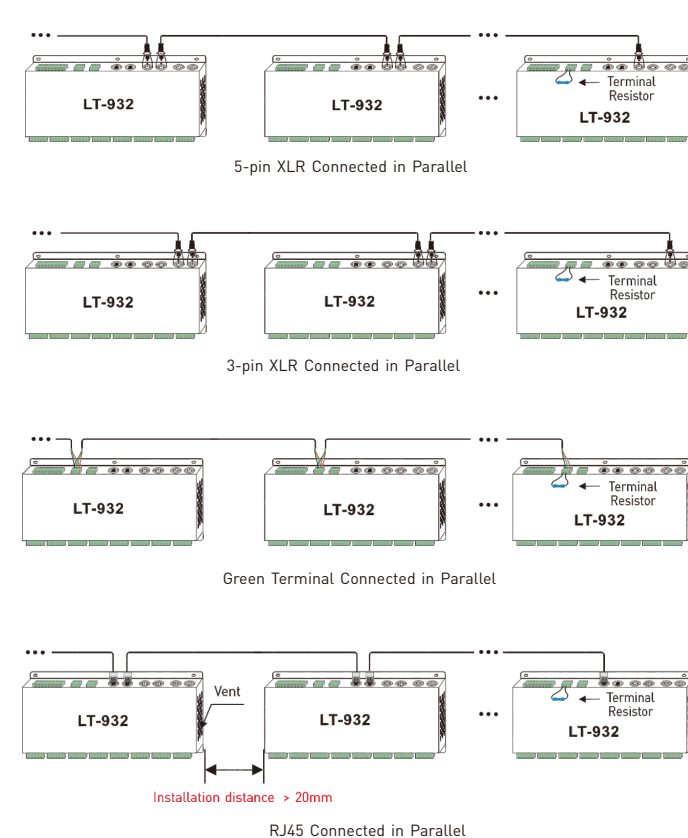

These 4 terminals can be connected in a mixed way.

* Installation Attention : please reserve enough ventilation distance between decoders (>20mm), be sure not to block the vent, or will affect lifetime of decoder for poor heat dissipation.

4. The connection diagram of AMP signal amplifier terminal:

* Connecting with green terminal or an extra amplifier will be needed when more than 32 decoders are connected or use overlong signal wire(as shown below). Signal amplifier should not be more than 5 times continuously.

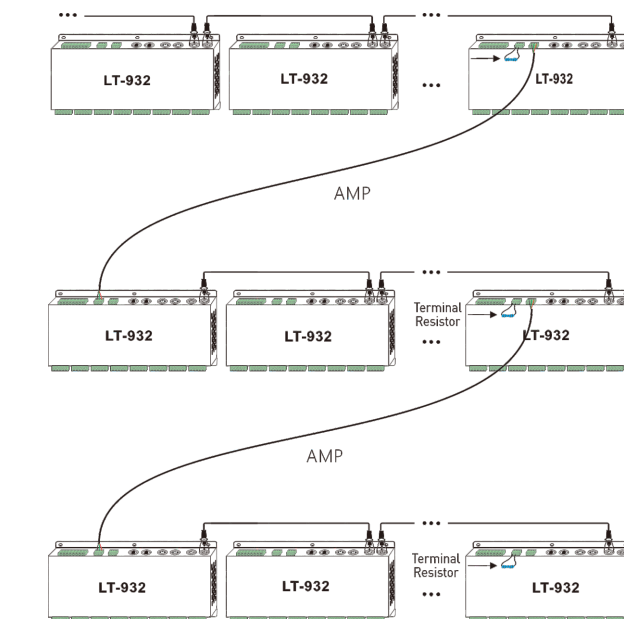

Attention:

1. The product shall be installed and serviced by the qualified person.
2. This product is non-waterproof. Please avoid the sun and rain. When installed outdoors please ensure it is mounted in a water proof enclosure.
3. Good heat dissipation will prolong the working life of the controller. Please ensure good ventilation.
4. Please check if the output voltage of the LED power supply used comply with the working voltage of the product.
5. Please ensure that adequate sized cable is used from the controller to the LED lights to carry the current. Please also ensure that the cable is secured tightly in the connector.
6. Ensure all wire connections and polarities are correct before applying power to avoid any damages to the LED lights.
7. If a fault occurs, please return the product to your supplier. Do not attempt to fix this product by yourself.

Warranty Agreement:

1. We provide lifelong technical assistance with this product:
 - A 5-year warranty is given from the date of purchase. The warranty is for free repair or replacement if cover manufacturing faults only.
 - For faults beyond the 5-year warranty, we reserve the right to charge for time and parts.
2. Warranty exclusions below:
 - Any man-made damages caused from improper operation, or connecting to excess voltage and overloading.
 - The product appears to have excessive physical damage.
 - Damage due to natural disasters and force majeure.
 - Warranty label, fragile label and unique barcode label have been damaged.
 - The product has been replaced by a brand new product.
3. Repair or replacement as provided under this warranty is the exclusive remedy to the customer. We shall not be liable for any incidental or consequential damages for breach of any stipulation in this warranty.
4. Any amendment or adjustment to this warranty must be approved in writing by our company only.

★ This manual only applies to this model. We reserve the right to make changes without prior notice.